

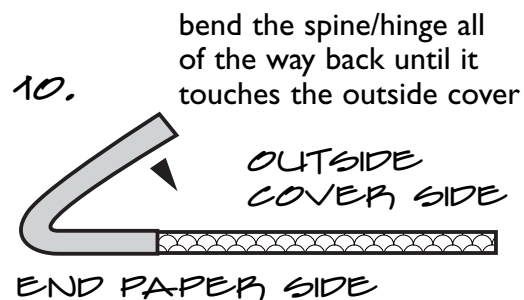

MAKING THE HINGE: Use pieces E plus both front and back covers.

to check the fit, first without glue, center one of the end papers, piece E, on the inside cover. Then apply glue and lay, do not smooth, the paper onto the inside cover. **Being careful** not to tear the end paper, slowly bend the spine all the way back until it touches the outside cover (the decorative paper side), **figure 10**. This will slide the end paper slightly away from the hinge edge of the cover.



place the cover end paper side up.

with a bone folder, tuck the resulting paper "bump" into the hinge, **figure 11**. Fold the hinge back a few more times to stretch the paper while it is wet with glue. Smooth the end paper down.

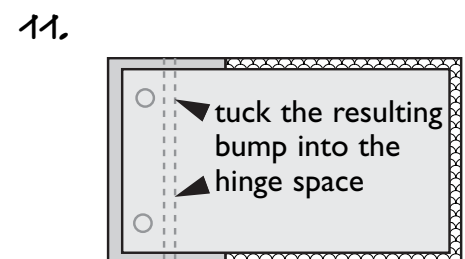

repeat the hole punching steps on the end paper, punching from the inside of the cover to the outside.

repeat the above steps for the second cover.



BINDING THE ALBUM:

place the clear pages onto the back cover. **Make sure the binding holes on the cover and the pages line up.**

bind the album by keeping the ribbon tight (see below). Using an awl or BBH T108 ribbon threading needle, push the end of the ribbon through the holes. **Push only on the end** because pushing elsewhere frays the ribbon.

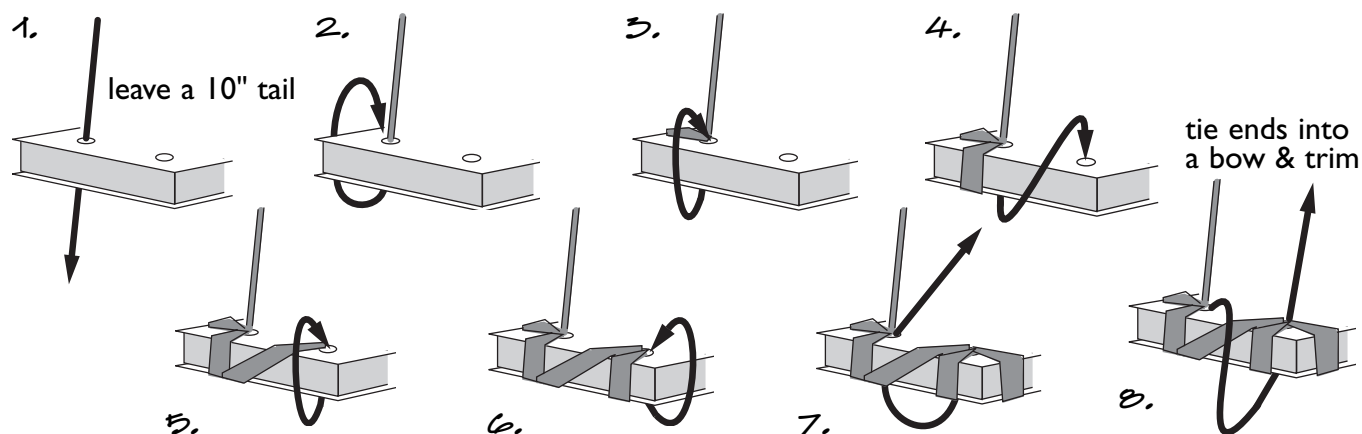

© 1999 Books By Hand



Ribbon-Bound Album

FOR THIS PROJECT YOU WILL NEED:

- scissors or craft knife
- small glue brush, 1/2" wide
- larger glue brush, 1" to 2" wide
- pencil
- ruler
- PVA (good quality paper glue)
- scrap paper to glue on
- tool to push ribbon through binding holes
- 2 weights (try a brick wrapped in kraft paper)
- wax paper to smooth out glued surfaces
- bone folder

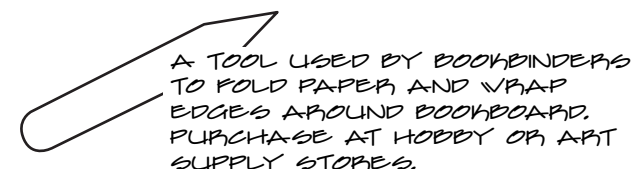

TO PREPARE FOR THIS PROJECT:

Clear a work space and do an inventory of all the pieces in this kit. Carefully measure each piece. With a pencil, lightly label each piece with the capitalized letter that corresponds with the list below, figures 1 and 2.

STRUCTURE: Bookboard and pages

- A** two pieces--1 1/4" x 5 1/2" bookboard with two holes (the spine)
- B** two pieces--8 1/4" x 5 1/2" bookboard (the front and back covers)
- twelve archival clear top load pages

COVER MATERIAL: Bookcloth is fabric backed with paper to create a glue barrier. Mark and glue only on the wrong, paper side.

- C** two pieces--7 1/2" x 6 3/4" decorative paper (front and back covers)
- D** two pieces--4" x 6 3/4" bookcloth (front and back spine)
- E** two pieces--9 1/4" x 5" paper, without holes, that matches the pages (covering for the inside of the front and back covers--the "end papers")

* no need to mark these pieces with a capitalized letter

RIBBON: 60" for binding the album

IMPORTANT!

Read and study the Glue Tips carefully before starting this project!

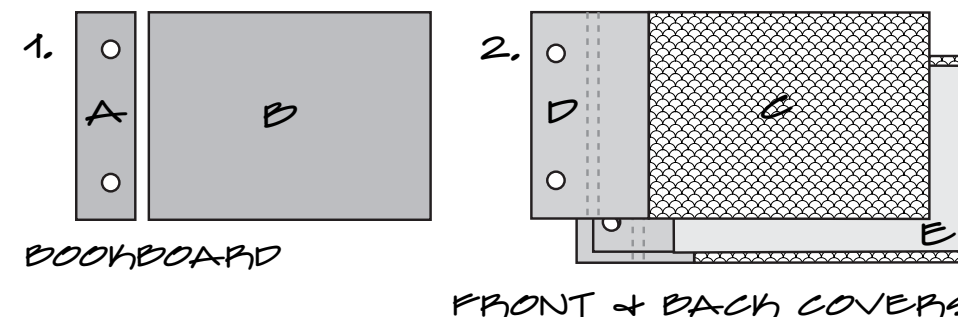

© 1999 Books By Hand





MAKING THE FRONT AND BACK COVERS: Use all of the remaining pieces except pieces E.

- work on one cover at a time.

- mark a bookboard spine, piece A, with an arrow pointing towards the long edge that the binding holes are closest to, **figure 3**. This will be the hinge side of the spine.

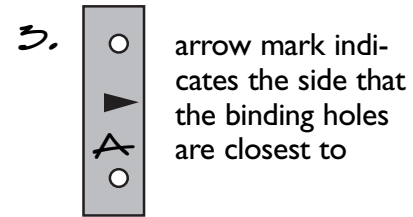

- place a bookcloth spine, piece D, wrong side up and apply glue. Glue the bookboard spine, piece A, onto the bookcloth, leaving approximately a $\frac{1}{2}$ " margin on the top, bottom and side edges opposite the arrow side of the spine piece, **figure 4**. Clip the two outside corners, ✓ **Glue Tips**.

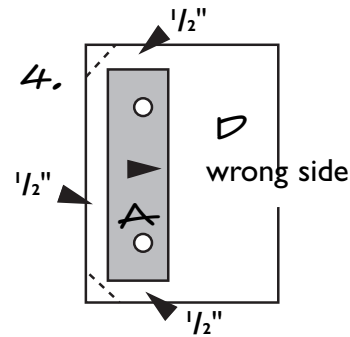

- measure $\frac{1}{4}$ " away from the arrow side of the spine and lightly mark the distance with a pencil, **figure 5**.

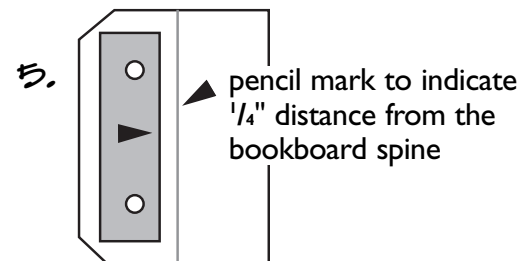

- apply glue to the exposed bookcloth and glue down a bookboard cover, piece B, leaving a $\frac{1}{4}$ " space between the spine and the cover, **figure 6**.

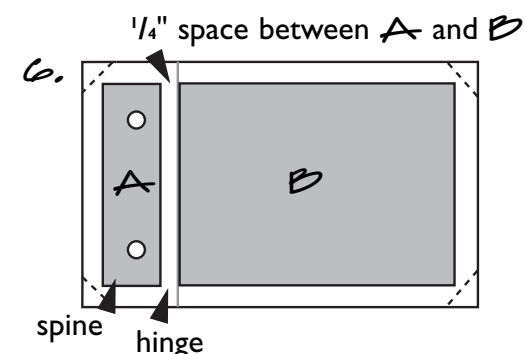

- apply glue to the exposed bookcloth edges and wrap them around the bookboard, ✓ **Glue Tips**.

©1999 Books By Hand



MAKING THE FRONT AND BACK COVERS: Continued.

- to check placement, before applying any glue, place decorative paper, piece C, wrong side up and lay the bookboard cover on top of it, **figure 8**. The decorative paper should overlap the bookcloth.

- apply glue to the wrong side of the decorative paper. Leaving the piece glue side up, move it to **clean scrap paper**.

- holding the cover at an angle away from the glue, rest the bookboard edge that is opposite the spine on the glue covered paper, leaving approximately a $\frac{1}{2}$ " margin on the top, bottom and side, **figure 7**.

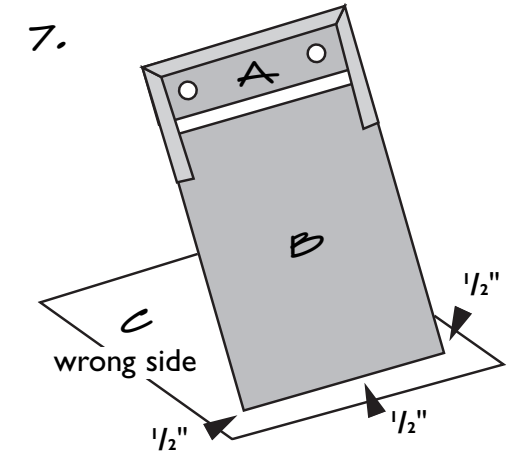

- after adjusting the cover, carefully lower it onto the decorative paper and smooth the paper down, **figure 8**.

- clip the two outside corners of the paper, ✓ **Glue Tips**. Apply glue and wrap the paper edges around the bookboard.

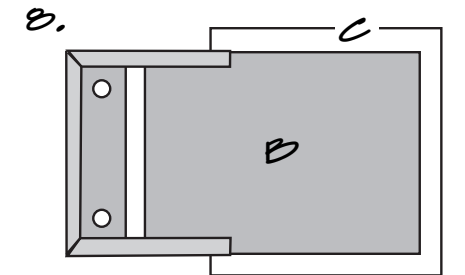

- repeat the above steps for the second cover.



PUNCHING THE BINDING HOLES: Do both front and back covers.

- dab a **very small** drop of glue into each binding hole on the inside of the cover.

- turn the piece over, and from the front of the cover, use a pencil point or some other pointed object, to punch holes through the bookcloth, **figure 9**. Make the holes as large as possible. This forces the bookcloth to be glued to the inside of the binding holes.

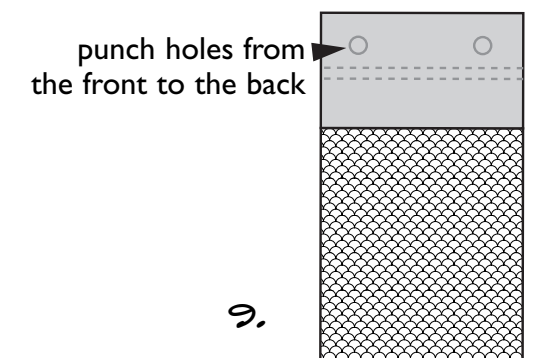

©1999 Books By Hand



We will send you a surprise if you let us know, in writing, about any typos or unclear instructions.